

Lithium-ion Battery

1 kWh - 12 V DC / 24 V DC / 48 V DC

Type M

A12010M

A24010M

A48010M

Version 1.0

Bedienungsanleitung

Deutsch

Operating Manual

English

Deutsch

English

Table of Contents

1.	Introduction.....	3
1.1.	General.....	3
1.2.	Terminology.....	4
1.3.	Explanation of Symbols.....	4
1.3.1.	Structure of the Safety Instructions.....	4
1.3.2.	Symbols, Warning Signs and Mandatory Signs.....	5
1.3.3.	Abbreviations.....	5
1.4.	Labelling.....	6
1.5.	Contact Address.....	6
2.	About the aentron Lithium-ion Battery	7
2.1.	Using the Lithium-ion Battery.....	7
2.1.1.	Intended Use.....	7
2.1.2.	Foreseeable Misuse.....	7
2.2.	Technical Data.....	8
2.2.1.	Dimensions.....	8
2.2.2.	Electrical Specification.....	8
2.2.3.	Additional Specifications.....	9
2.2.4.	Ambient Conditions.....	9
2.2.5.	Standby Current Consumption.....	9
2.3.	Scope of Delivery.....	10
2.3.1.	Versions of the Lithium-ion Battery.....	10
3.	Safety.....	11
3.1.	Basic Functional Safety.....	11
3.2.	Warnings of a General Nature.....	11
3.3.	Thermal Hazards.....	12
3.4.	Electrical Hazards.....	13
3.5.	Dangers Caused by Materials and Substances.....	13
3.6.	Safety Equipment.....	13
4.	Preparation for Use.....	14
4.1.	Layout and Controls.....	14
4.1.1.	LED Definition.....	15
4.2.	Interfaces External Systems.....	15
4.3.	Transport and Storage.....	17
4.3.1.	Unpacking.....	18
4.4.	Installation.....	18
4.4.1.	Installation Location of the Lithium-ion Battery.....	18
4.4.2.	Electrical Connection.....	19
4.4.3.	Checking the Functions.....	20

4.5.	Commissioning	20
5.	Operation the Lithium-ion Battery	21
5.1.	General	21
5.2.	Modes of Operation	21
5.2.1.	Parallel Connection	22
5.3.	Normal Operation	23
5.3.1.	Starting as a Stand-Alone Solution	23
5.3.2.	Charging	24
5.3.3.	Charging Method	25
5.3.4.	Charge Equalisation	25
5.3.5.	Saving Power	25
6.	Cleaning, Maintenance and Care	26
6.1.	Cleaning and Care	26
6.2.	Maintenance	26
6.3.	Servicing and Repairs	26
7.	Decommissioning and Disposal	27
7.1.	Decommissioning	27
7.2.	Storage	28
7.3.	Winter Storage.....	29
7.4.	Disposal and Recycling	29
8.	Faults and Notifications	30
8.1.	Troubleshooting.....	30
8.2.	Emergencies.....	32
8.3.	Frequently Asked Questions (FAQ)	32
9.	Legal Information	35
9.1.	Warranty Conditions	35
9.2.	Copyright and Property Rights	35
9.3.	Material and Legal Defects.....	35
9.4.	Approvals and EU Declaration of Conformity.....	36

1. Introduction

1.1. General

This operating manual enables the safe and efficient handling of the aentron lithium-ion battery and describes all the essential functions.

This operating manual ensures the safe operation of the lithium-ion battery in accordance with the intended use.

This document contains:

- Description of the design, functions and features of the lithium-ion battery
- Notes on possible dangers, their consequences and on measures for hazard prevention
- Detailed specifications on the standard operation of the lithium-ion battery.

The operating manual must be stored away safely for users to be able to access at any time. Please read the operating manual carefully before placing the lithium-ion battery into operation.

For the safe and efficient use, all the safety instructions and handling instructions of this operating manual must be read and understood. Furthermore, we recommend following the requirements of EN ISO 16315:2016 for the integration and professional installation of the lithium-ion battery.

In this operating manual, the latest version of the lithium-ion battery is described. If changes or supplements are required in the future, the operating manual is amended, and all amendment are included in the next revision.

The respective version of the operating manual is displayed on the cover sheet and in the footer; this operating manual is version "1.0". The version will be increased by "1" with every revision.

aentron GmbH reserves the right to make changes to systems and documentation without notifying users of previous versions.

TIP



If the lithium-ion battery is passed or sold on to third parties, the following documents must be passed on to the new user:

- ▶ This operating manual
- ▶ Documentation of repair work carried out.

1.2. Terminology

Cell

The cell is the smallest part of an electrochemical storage system and stores the chemical energy.

Module

A grouping of multiple cells or cell blocks, fitted with a battery management system.

Battery

A battery refers to when several modules are connected in parallel or in series.

Battery system

If several modules are connected in parallel or in series and are managed by an energy controller, this is referred to as a battery system.

1.3. Explanation of Symbols

1.3.1. Structure of the Safety Instructions

The safety instructions in this document are presented with a standardised format and symbols. Depending on the probability of occurrence and the severity of the consequences, the following hazard classes are used:

WARNING



Indicates a hazardous situation which could lead to serious physical injury or burns.

- ▶ Measures for preventing the hazard

NOTICE

Indicates a situation that could lead to property damage.

- ▶ Measure for preventing the property damage

TIP



Application tips and particularly useful information

1.3.2. Symbols, Warning Signs and Mandatory Signs



Warning of a hazard point



Warning of electrical voltage



Warning of corrosive substances



Warning of a fire hazard



Application tips and other useful information

Symbols on the Lithium-ion Battery



Pay attention to the manual



Not for disposal with domestic waste



CE mark

1.3.3. Abbreviations

- E-Switch = Electronic switch
- C-Rate = Current to charge the battery in 1 hour
- SoC = State of Charge of the Battery
- DoD = Depth of Discharge
- BMS = Battery Management System
- BLK = Black
- CAN = Controller Area Network / Serial Bus System
- GND = Chassis Ground
- CCCV = Constant Current, Constant Voltage

1.4. Labelling

Every lithium-ion battery from aentron GmbH is fitted with a type plate. This is located on the front / top of the lithium-ion battery.

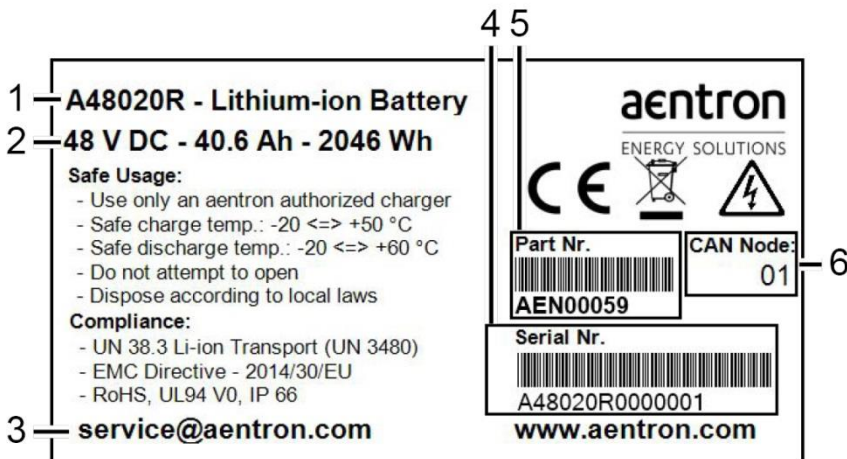

Figure 1 Type plate (example)

- 1 Type name
- 2 Voltage, Capacity, Energy
- 3 Contact details
- 4 Serial number
- 5 Part number
- 6 CAN node ID number

1.5. Contact Address

aentron GmbH - Energy Solutions
Friedrichshafener Straße 7
82205 Gilching
GERMANY
Phone: +49 8105 398 98-0
Fax: +49 8105 398 98-29
www.aentron.com
info@aentron.com

2. About the aentron Lithium-ion Battery

2.1. Using the Lithium-ion Battery

The aentron lithium-ion battery has been designed so that it can be used as a modular assembly, either as a single device or in a parallel configuration with other appropriate lithium-ion batteries of the same capacity and power of up to 60 V.

The modular concept of the lithium-ion batteries enables scalable configurations of up to a maximum of 4 modules in parallel of up to 60 Vdc, without a higher-level control system being required. The lithium-ion batteries in conjunction with our integrated Battery Management System (BMS) are therefore designed and configured for high performance and safe operation.

All lithium-ion batteries have galvanic isolation to ground > 1,000 Vdc. Thanks to the integrated BMS, all safety-related parameters of the lithium-ion battery - such as over / undervoltage, over-current, over / under temperature, cable breaks and charge level - are continuously monitored.

2.1.1. Intended Use

The lithium-ion battery is equipped with the latest Li-NMC cell technology and is designed for the following applications:

- E-Industry
- E-Maritime
- E-Mobility
- ON / OFF grid

The lithium-ion battery can be operated as a stand-alone solution or used in a parallel connection with a maximum of 4 x lithium-ion batteries. Should you require greater capacities, please contact your authorised aentron dealer.

The limits to use described in this user manual must always be complied with.

The lithium-ion battery must only be used for purposes described in this user manual.

2.1.2. Foreseeable Misuse

Use of the lithium-ion battery other than or in addition to that described in chapter 2.1.1. Intended Use is considered to be improper use, meaning incorrect use, and this leads to warranty invalidation.

This applies in particular to the use of the lithium-ion battery for applications in medical or aerospace industries.

2.2. Technical Data

The conditions at the location of usage of the lithium-ion battery must match the conditions which are presented as permissible ambient conditions in this operating manual.

aentron GmbH assumes no liability for damage arising from use in different conditions.

2.2.1. Dimensions

12 Vdc / 24 Vdc / 48 Vdc - 1 kWh Li-ion Type M (100 A)	
Length [mm]	360
Width [mm]	160
Depth [mm]	90
Weight [kg]	Approx. 9

2.2.2. Electrical Specification

12 Vdc / 24 Vdc / 48 Vdc - 1 kWh Li-ion Type M (100 A)	
Nominal voltage [Vdc]	12 / 24 / 48
Operating voltage [Vdc]	10 to 16 / 21 to 28 / 42 to 57
aentron ID	A12010M / A24010M / A48010M
Article no.	AEN00273 / AEN00161 / AEN00328
Capacity [Ah]	70 / 40 / 20
Power [Wh]	1000
Max. peak current	100 A (M) @ 10 sec
Continuous current [A]	60
Control system	E-Switch, Status LED

2.2.3. Additional Specifications

Configuration	Max.: 60 V / 4 x parallel (4 kWh)
Technology	Li-NiCoMnO ₂
Cell balance	Passive (150 mA)
Cooling concept	Passive
Service life	> 5 years (+20 °C)
Approvals	UN 38.3, CE, RoHS
Cycles (full)	> 3,000 (80 % Kp @ +20 °C)
Fast charging	0.5 - 2 C
Housing material	Aluminium die casting
Feed terminal	RADLOK 5.7 mm (RED & BLK)

2.2.4. Ambient Conditions

Recommended operating temperature range [°C]	0 to +30
Max. Component standby temperature [°C]	+80
Min. operating temperature [°C]	-20
Max. operating temperature [°C]	+60
Charging temperature range [°C]	+0 to +50
Relative humidity [%]	5 - 95
Transport / delivery conditions	-20 °C to +30 °C at 65 % ambient humidity
Ingress protection (IP) class	IP66
UL flammability class	UL94 V0
Operating height [m]	< 4,000

2.2.5. Standby Current Consumption

Standby current consumption until the lithium-ion battery switches to deep-discharge protection

1 kWh Li-ion - Type M standby status	Load (W)	SoC (%)	12 Vdc / 24 Vdc / 48 Vdc Time until deep discharge
E-Switch ON	0.05	100	20,000 hours / 833 days
E-Switch ON	0.05	50	10,000 hours / 416 days
E-Switch ON	0.05	5	1,000 hours / 41 days
E-Switch ON	0.05	1	200 hours / 8 days

2.3. Scope of Delivery

1 kWh - Type M and 12 V, 24 V, 48 V

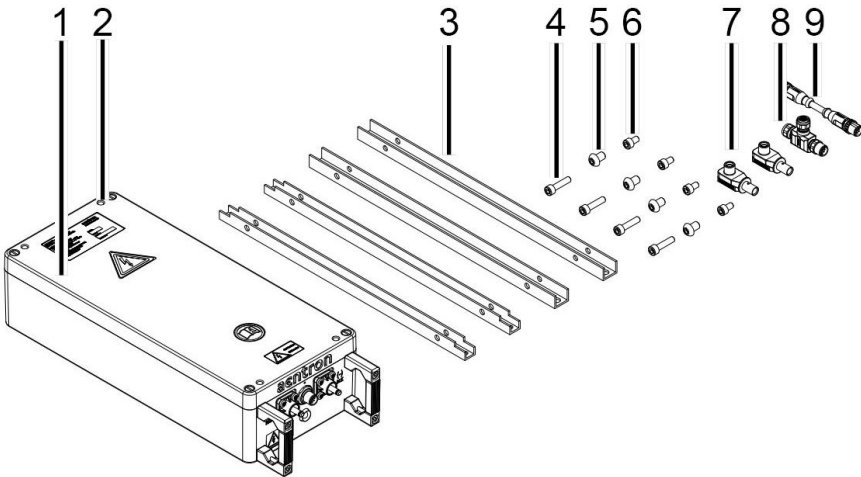

Figure 2 Scope of Delivery (1 kWh - Type M)

- 1 Energy storage system
- 2 4 x cover mounting holes (M6 x 20 mm)
4 x base mounting holes (M8 x 30 mm)
- 3 Mounting rail set*
- 4 4 x fixing screws (M6 x 25 mm) for horizontal rails*
- 5 4 x fixing screws (M8 x 16 mm) for support rails*
- 6 4 x fixing screws (M6 x 10 mm) for cover rails*
- 7 (+) / (-) power connection sockets (5.7 mm)
- 8 T-piece communications connector (8-pin) for parallel connection*
- 9 Communications cable (8-pin)*

* Optional - Available separately and dependent on the configuration

2.3.1. Versions of the Lithium-ion Battery

Type M - 1 kWh

- A12010M - 12 V - 1 kWh
- A24010M - 24 V - 1 kWh
- A48010M - 48 V - 1 kWh

You can find the technical specifications of the individual versions in chapter 2.2. Technical Data.

3. Safety

You can find a detailed explanation of the safety and warning symbols in chapter 1.3. Explanation of Symbols.

Special safety regulations may apply to particular activities. Safety and warning signs for such activities can be found in the respective chapters of this operating manual.

3.1. Basic Functional Safety

For the operation of the lithium-ion battery, safety, accident prevention and environmental protection regulations must also be followed.

Only use the lithium-ion battery:

- For its intended purpose, in a safe and hazard-conscious manner and by paying attention to this operating manual.
- If all safety equipment is present and fully functional.
- If the lithium-ion battery is in a technically flawless condition.

This also includes:

- The warning signs and labels attached on the lithium-ion battery must always be complete and in a legible condition. Replace damaged or illegible signs. Please refer to your authorised aentron dealer.
- Only perform installation, cleaning and / or disassembly work when the lithium-ion battery is switched off.

NOTICE

Physical damage to the lithium-ion battery due to excessive current flow through voltage compensation.

- ▶ Prior to connecting in parallel, measure the respective voltage of the individual lithium-ion batteries.
Make sure that the voltages between the individual lithium-ion batteries DO NOT deviate > 1 Vdc.

3.2. Warnings of a General Nature

- ONLY take the lithium-ion battery out of the original packaging if it is required for use.
- DO NOT subject the lithium-ion battery to any excessive mechanical shocks; e. g. from dropping.
- DO NOT remove the attached handles which are required for preventing accidental drop damage.

- The pressure-equalisation membrane must NOT be blocked or covered. The lithium-ion battery does not need any extra ventilation under normal operating conditions.
- In addition, you should fit your application with an electric fuse which is rated lower than the fuse of the lithium-ion battery (e. g. 10 % to 20 % lower). Please note the technical data of the lithium-ion battery in this regard.
Type M fuse: 100 A
- If the internal fuse of the lithium-ion battery fails, please refer to your authorised aentron dealer for support and repairs.
DO NOT attempt to replace the fuse, otherwise the warranty for the lithium-ion battery will be invalidated.
- ONLY use chargers which have been authorised by aentron GmbH.
- Ensure correct polarity when connecting the lithium-ion battery and the charger.
- DO NOT combine or mix different manufacturers, capacities, sizes or types of other battery technologies with the lithium-ion battery.
- ONLY use the lithium-ion battery for the intended application and power; see chapters 2.1.1. Intended Use and 2.2. Technical Data.
- Ensure that the voltages between the individual lithium-ion batteries DO NOT deviate > 1 Vdc for every parallel connection.
- The lithium-ion battery boasts IP protection class 66, and is thus splash-proof. It should, however, not be subjected to wet conditions continuously for its own protection.
- Switch the lithium-ion battery off when not in use.
- Store away the original packaging for servicing / repairs / disposal at the end of the service life.

3.3. Thermal Hazards



Risk of fire possible due to overheating of the lithium-ion battery.

- ▶ DO NOT subject the lithium-ion battery to any excessive heat or fire ($> +60$ °C).
- ▶ Pay attention to the safety instructions attached to the lithium-ion battery.
- ▶ DO NOT exceed the permissible temperature ranges; see chapter 2.2.4. Ambient Conditions.
- ▶ DO NOT leave the lithium-ion battery switched on with exposed terminals. This could lead to a short circuit.

- ▶ In the event of a fire, use a CO₂ fire extinguisher or a fire extinguisher with non-conductive foam. Please proceed as follows:
 - Step 1: **Extinguish** with CO₂ fire extinguisher / fire extinguisher with non-conductive foam
 - Step 2: **Cool** with CO₂ fire extinguisher / fire extinguisher with non-conductive foam
 - Step 3: **Isolate** -> Place the lithium-ion battery in a secure location for at least seven days and also cover it with sand.
- ▶ Remove the lithium-ion battery in the event of a short circuit or overcharge and isolate it for 24 - 48 hours to prevent internal cell short circuit (slow-burn short circuit). Refer to your authorised aentron dealer immediately for further assistance.

3.4. Electrical Hazards



Fatal electric shock possible due to improper handling of the lithium-ion battery.

- ▶ DO NOT attempt to open, repair or disassemble the lithium-ion battery.
- ▶ Repairs must only be performed by specialist personnel authorised by aentron GmbH.

3.5. Dangers Caused by Materials and Substances



Risk of corrosion possible due to the lithium-ion battery leaking.

- ▶ In the event of the lithium-ion battery leaking, the fluid must not come into contact with the skin or the eyes.
- ▶ In the event of contact, rinse the affected area with plenty of water and seek medical attention.

3.6. Safety Equipment

BMS - Battery Management System

Thanks to the integrated BMS, all safety-related parameters of the lithium-ion battery - such as over / undervoltage, over-current, over / under temperature, cable breaks and charge level - are continuously monitored.

4. Preparation for Use

4.1. Layout and Controls

1 kWh - Type M and 12 V, 24 V, 48 V

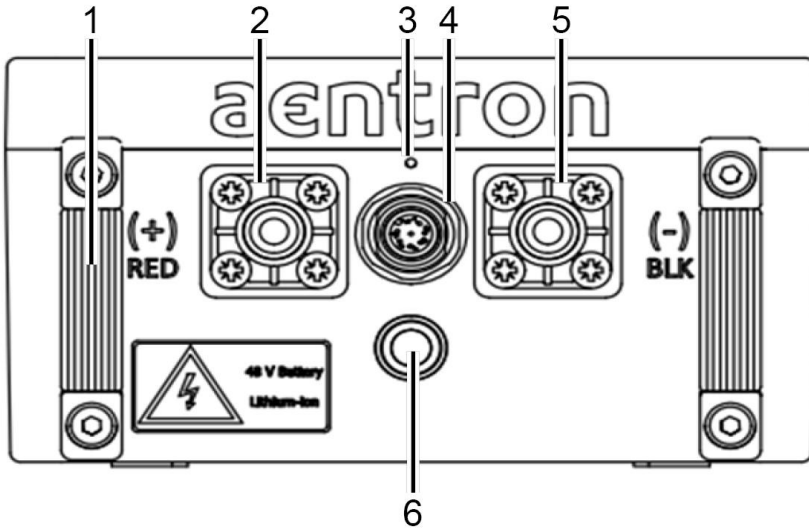

Figure 3 Interfaces and controls (1 kWh Type M)

- 1 Handle
- 2 (+) power interface (5.7 mm)
- 3 Pressure-equalisation membrane
- 4 Communications connector (8-pin) for parallel connections
- 5 (-) power interface (5.7 mm)
- 6 Status LED / charge status SoC

Power Interface

- (+) terminal; red RADLOK:
5.7 mm (0 to 1000 V to 500 A) /
-40 to +125 °C
- (-) terminal; blk RADLOK:
5.7 mm (0 to 1000 V to 500 A) /
-40 to +125 °C

4.1.1. LED Definition

LED	SoC (%)	12 Vdc	24 Vdc	48 Vdc	Mode
flashing red	-5	< 12 V	< 21 V	< 41 V	Shutdown mode / Immediate charging
red	0	> 12 V	> 21 V	> 41 V	Shutdown mode / Battery empty
yellow	20	> 13 V	> 23 V	> 45 V	Warning: charge level low
green	50	> 14 V	> 25 V	> 50 V	Normal operation
flashing green	100	> 15.5 V	> 27 V	> 55 V	Battery full
green / red	105	> 17 V	> 30 V	> 59 V	Battery in overcharged condition / Terminate charging process immediately

4.2. Interfaces External Systems

Parallel Module Configurations: Communication Module

Type M with optional 8-pin communications connector - maximum 4 x modules connected in parallel with the integrated E-Switch

Function	Signal	Range (Type M)
PIN 1 (white)	Module 1 input	High / Low
PIN 2 (brown)	Module 1 input	High / Low
PIN 3 (green)	Module 2 input	High / Low
PIN 4 (yellow)	Module 2 input	High / Low
PIN 5 (gray)	Module 3 input	High / Low
PIN 6 (pink)	Module 3 input	High / Low
PIN 7 (blue)	Module 4 input	High / Low
PIN 8 (red)	Module 4 input	High / Low

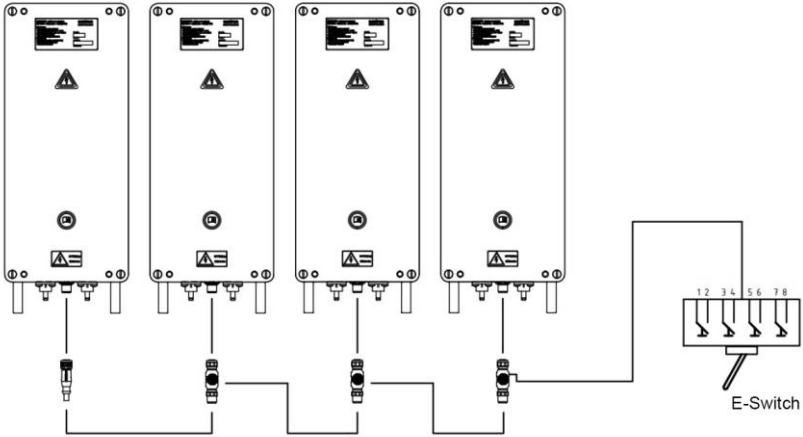

Figure 4 Parallel module configuration (1 kWh - Type M)

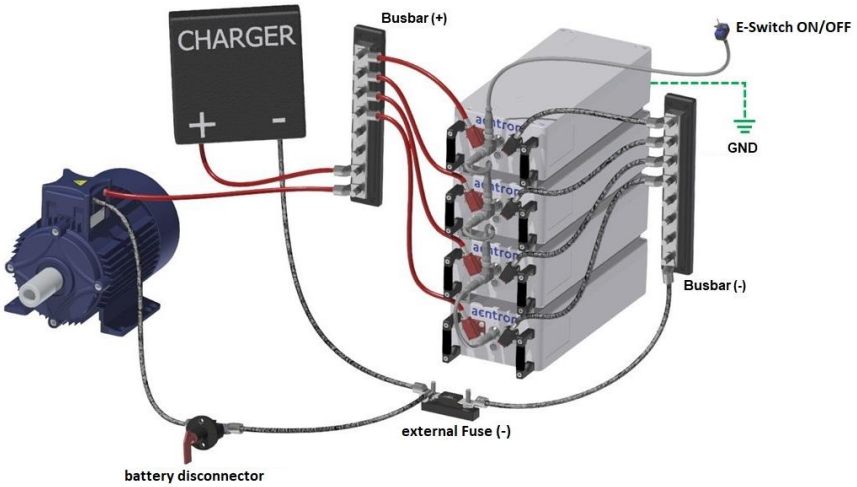

Figure 5 Parallel module configuration - Example (1 kWh - Type M)

4.3. Transport and Storage

WARNING



Risk of fire possible due to overheating of the lithium-ion battery.

- ▶ DO NOT subject the lithium-ion battery to excessive heat or fire (> +60 °C).
- ▶ Avoid storage in areas exposed to direct sunlight.
- ▶ Store the lithium-ion battery in a dry and protected location. Pay attention to the storage conditions; see chapter 2.2.4. Ambient Conditions.
- ▶ In the event of a fire, use a CO₂ fire extinguisher or a fire extinguisher with non-conductive foam. Please proceed as follows:
 - Step 1: **Extinguish** with CO₂ fire extinguisher / fire extinguisher with non-conductive foam
 - Step 2: **Cool** with CO₂ fire extinguisher / fire extinguisher with non-conductive foam
 - Step 3: **Isolate** -> Place the lithium-ion battery in a secure location for at least seven days and also cover it with sand.
- ▶ Remove the lithium-ion battery in the event of a short circuit or overcharge and isolate it for 24 - 48 hours to prevent internal cell short circuit (slow-burn short circuit).

The lithium-ion battery is transported in accordance with the requirements of UN38.3 on the transport of dangerous goods.

Store away the original packaging for servicing / repairs / disposal at the end of the service life.

In case of any doubt, please refer to your authorised aentron dealer.

TIP



Shipping a lithium-ion battery without approved packaging may lead to penalties and fines.

Store the lithium-ion battery in the original packaging in a dry and protected location. Observe the transport / storage conditions:

-20 °C to +30 °C at 65 % ambient humidity

4.3.1. Unpacking

Immediately after delivery, check the condition of the lithium-ion battery and all electrical interfaces for damage. Check the completeness of the delivery using the delivery note.

Record any transport damage in writing and report this immediately to the freight forwarder and aentron GmbH or your authorised aentron dealer.

4.4. Installation

4.4.1. Installation Location of the Lithium-ion Battery

For the location of installation of the lithium-ion battery, please pay attention to the ambient conditions; see chapter 2.2.4. Ambient Conditions.

The lithium-ion battery has 4 x mounting holes, both on the cover and on the base of the module (see Figure 2).

Fix the lithium-ion battery using the mounting holes, fixing screws and, if necessary, the mounting rail sets.

The lithium-ion battery can be installed in any angle of orientation.

The mounting rail set is an optional extra and is available separately if required. For further information, please refer to your authorised aentron dealer.

4.4.2. Electrical Connection

WARNING



Fatal electric shock possible due to improper handling of the lithium-ion battery.

- ▶ DO NOT connect the lithium-ion battery to an AC power source.
- ▶ DO NOT connect the lithium-ion battery in series > 60 Vdc.
- ▶ Pay attention to the (+) and (-) marks on the lithium-ion battery.
- ▶ During installation, first connect the (+) pole and then the (-) pole, to prevent excessive electrostatic discharge (sparks).
- ▶ Fit your application with an electric fuse which is rated lower than the fuse of the lithium-ion battery (e. g. 10 % to 20 % lower). Please note the technical data of the lithium-ion battery in this regard. Type M fuse: 100 A
- ▶ If the internal fuse of the lithium-ion battery fails, please refer to your authorised aentron dealer for support and repairs. DO NOT attempt to replace the fuse, otherwise the warranty for the lithium-ion battery will be invalidated.

NOTICE

Physical damage to the lithium-ion battery due to excessive current flow through voltage compensation.

- ▶ Prior to connecting in parallel, measure the respective voltage of the individual lithium-ion batteries. Make sure that the voltages between the individual lithium-ion batteries DO NOT deviate > 1 Vdc.

To connect the lithium-ion battery, please proceed as follows:

1. Make sure that the lithium-ion battery is switched off and the status LED is NOT illuminated.
 2. Connect the supplied (+) RED cable to the correspondingly marked (+) RED power terminal.
 3. Connect the supplied (-) BLK cable to the correspondingly marked (-) BLK power terminal.
 4. Make sure that the RADLOK connectors latch in correctly so that a secure electrical connection is ensured.
 5. Set the power switch to ON.
- ➔ The status LED lights up in accordance with the current charge level after 2 seconds.
- ✓ The lithium-ion battery is ready for operation.

4.4.3. Checking the Functions

To check the functionality of your lithium-ion battery, proceed as follows:

1. Switch the lithium-ion battery on.
➔ The status LED lights up in accordance with the current charge level after 2 seconds.
The status LED should light up either yellow or green.
2. Use a multimeter to check that the voltage is within the delivery range defined in the following table.

LED	SoC (%)	12 Vdc	24 Vdc	48 Vdc
yellow	20	≥ 13 V	≥ 23 V	≥ 45 V
green	50	≤ 14 V	≤ 25 V	≤ 50 V

- ➔ If the voltage deviates from the defined range, refer to your authorised aentron dealer.
- ➔ If the voltage is in the defined range, the lithium-ion battery can be used.
- ✓ The function check is complete.

4.5. Commissioning

In order to put your lithium-ion battery into operation, proceed as follows:

1. Switch the lithium-ion battery on.
➔ The status LED lights up in accordance with the current charge level after 2 seconds.
The status LED should light up either yellow or green.
2. Use a multimeter to check that the voltage is within the delivery range defined in the following table.

LED	SoC (%)	12 Vdc	24 Vdc	48 Vdc
yellow	20	≥ 13 V	≥ 23 V	≥ 45 V
green	50	≤ 14 V	≤ 25 V	≤ 50 V

- ➔ If the voltage deviates from the defined range, refer to your authorised aentron dealer.
- ➔ If the voltage is in the defined range, the lithium-ion battery can be used.
- 3. Charge the lithium-ion battery completely before using it.
- ✓ The lithium-ion battery is ready for operation.

5. Operation the Lithium-ion Battery

5.1. General

WARNING



Risk of fire possible due to overheating of the lithium-ion battery.

- ▶ Operate the lithium-ion battery exclusively in accordance with the electrical specifications and the ambient conditions; see chapter 2.2. Technical Data.
- ▶ DO NOT use the lithium-ion battery in a combustion engine chamber.
- ▶ Avoid operation of the lithium-ion battery in temperatures $> +40\text{ °C}$, as this could lead to premature ageing of the lithium-ion battery.
- ▶ Ensure the charging temperature range of 0 °C to $+50\text{ °C}$.

5.2. Modes of Operation

Normal Operating Mode

The lithium-ion battery is in normal mode when it responds to electrical charging and load currents.

Safety Mode

The lithium-ion battery is in safety mode when the BMS detects over / undervoltage, over-current, over / under temperature or a short circuit.

The function of the lithium-ion battery is blocked until the condition over / undervoltage is resolved.

Shutdown Mode

In shutdown mode, the lithium-ion battery stops all normal functions and there is no power at the feed terminal.

5.2.1. Parallel Connection

NOTICE

Physical damage to the lithium-ion battery due to excessive current flow through voltage compensation.

- ▶ Prior to connecting in parallel, measure the respective voltage of the individual lithium-ion batteries. Make sure that the voltages between the individual lithium-ion batteries DO NOT deviate $> 1 \text{ Vdc}$.

Make sure that the lithium-ion batteries are connected so that the current is distributed evenly to the lithium-ion batteries; see connection diagram Figure 6.

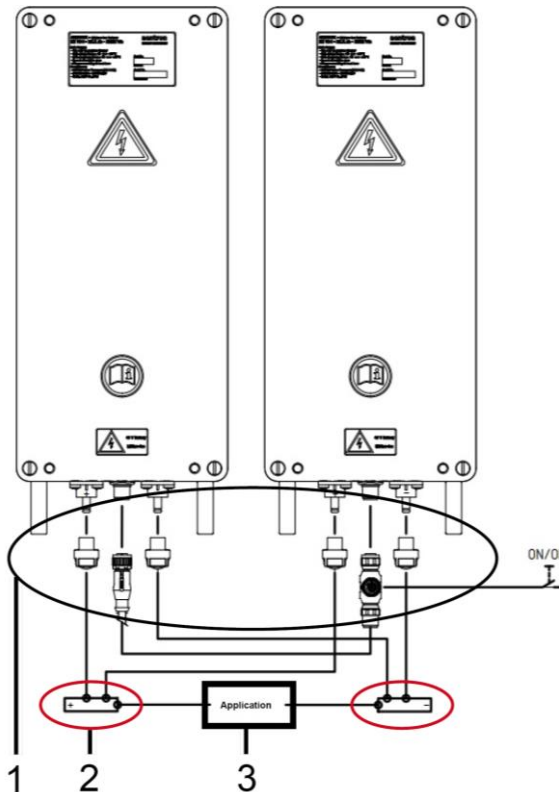

Figure 6 Parallel connection (1 kWh Type M)

- 1 Component ports
- 2 Busbar
- 3 Consumer

5.3. Normal Operation

5.3.1. Starting as a Stand-Alone Solution

To start your lithium-ion battery as a stand-alone solution, proceed as follows:

1. Switch the lithium-ion battery on.
 - ➔ The status LED lights up in accordance with the current charge level after 2 seconds.
The status LED should light up either yellow or green.
2. Use a multimeter to check that the voltage is within the delivery range defined in the following table.

LED	SoC (%)	12 Vdc	24 Vdc	48 Vdc
yellow	20	≥ 13 V	≥ 23 V	≥ 45 V
green	50	≤ 14 V	≤ 25 V	≤ 50 V

- ➔ If the voltage deviates from the defined range, refer to your authorised aentron dealer.
 - ➔ If the voltage is in the defined range, the lithium-ion battery can be used.
3. Charge the lithium-ion battery completely before using it.
 - ✓ The lithium-ion battery is ready for operation.

5.3.2. Charging

TIP



Secondary cells and lithium-ion batteries must be charged before use. ONLY use chargers which have been authorised by aentron GmbH. Make sure that you use an appropriate charger based on the battery voltage of your lithium-ion battery; see table.

Rated voltage	U _{min} charge	U _{max} charge
12 Vdc	10.0 V	16.4 V
24 Vdc	17.0 V	28.7 V
48 Vdc	35.0 V	57.4 V

To charge the lithium-ion battery, proceed as follows:

1. Make sure to use a charger authorised by aentron GmbH.
2. Make sure that the lithium-ion battery is switched off and the status LED is NOT illuminated.
3. Connect the supplied (+) RED cable to the correspondingly marked (+) RED power terminal.
4. Connect the supplied (-) BLK cable to the correspondingly marked (-) BLK power terminal.
5. Make sure that the RADLOK connectors latch in correctly so that a secure electrical connection is ensured.
6. Set the power switch to ON.
➔ The status LED lights up in accordance with the current charge level after 2 seconds.
7. Switch the charger on.
➔ The charging process starts automatically within 5 seconds.
The charging process terminates automatically once the process is complete.
- ✓ The lithium-ion battery is fully charged.
The status LED flashes green.

5.3.3. Charging Method

The lithium-ion batteries are optimally charged based on the CCCV method at an ideal temperature of +10 °C to +30 °C.

Furthermore, all chargers recommended by aentron GmbH are fitted with a float charging function with a maximum float delta of 1 V. This ensures that the lithium-ion battery is always fully charged and that the long-term strain of the lithium-ion battery is minimised at high SoC values.

5.3.4. Charge Equalisation

After switching off the lithium-ion battery, the power terminals (+) and (-) are electrostatically discharged to 0 Vdc within ten seconds.

5.3.5. Saving Power

The lithium-ion battery Type M has low self-discharge (< 0.05 W). Nevertheless, we recommend switching off the lithium-ion battery or connecting it to a charger when it is not in use.

The optimum long-term storage range is a SoC of between 30 % to 50 %.

6. Cleaning, Maintenance and Care

6.1. Cleaning and Care

NOTICE

Physical damage to the lithium-ion battery possible due to incorrect cleaning.

- ▶ NEVER use petrol, thinning agents, alcohol or other solvents. Otherwise discolouration and / or deformation may occur.

Cleaning must be performed based on the degree of soiling:

1. Switch the lithium-ion battery off.
 2. Disconnect all electrical connections to the lithium-ion battery.
 3. Clean the lithium-ion battery terminals with a clean, dry, lint-free cloth.
 4. Check the housing of the energy storage system for damage.
- ✓ The cleaning is complete.

6.2. Maintenance

The lithium-ion battery is maintenance-free in normal operation.

6.3. Servicing and Repairs

If the lithium-ion battery needs repairing during the warranty period, please contact your authorised aentron dealer.

Remove all devices that do not come from aentron GmbH.

Send the lithium-ion battery for repair to an authorised aentron dealer appointed by aentron GmbH.

For shipping, remember that the lithium-ion battery must ONLY be transported in the original packaging or newly delivered transport packaging in accordance with the requirements of UN38.3 on the transport of dangerous goods.

Please note our servicing conditions and T&Cs at www.aentron.com/support and www.aentron.com/agb

7. Decommissioning and Disposal

7.1. Decommissioning

WARNING



Fatal electric shock possible due to improper handling of the lithium-ion battery.

- ▶ During decommissioning, first disconnect the (-) pole and then the (+) pole, to prevent excessive electrostatic discharge (sparks).
- ▶ Insulate the electrical ports with sticky tape once the lithium-ion battery has reached the end of its service life.

To decommission the lithium-ion battery, proceed as follows:

1. Make sure that the lithium-ion battery is switched off and the status LED is NOT illuminated.
2. Remove the (-) BLK cable from the power terminal (-) BLK.
3. Remove the (+) RED cable from the power terminal (+) RED.
- ➔ The electrical connection of the lithium-ion battery has been removed.
4. If necessary, remove the E-Switch connections.
5. Remove the lithium-ion battery from the mounting rail set.
6. If necessary, disassemble the mounting rail set.
- ✓ The lithium-ion battery has been decommissioned.

7.2. Storage

TIP



When storing for over twelve months, charge the lithium-ion battery up to a minimum of 50 % SoC (status LED = constant green).

- Clean the lithium-ion battery and the electrical ports with a clean, dry, lint-free cloth.
- Pack the lithium-ion battery in the original packaging.
- When putting into storage, note the transport / storage conditions; see chapter 2.2.4. Ambient Conditions.

WARNING



Risk of fire possible due to overheating of the lithium-ion battery.

- ▶ DO NOT subject the lithium-ion battery to excessive heat or fire (> +60 °C).
- ▶ Avoid storage in areas exposed to direct sunlight.
- ▶ Store the lithium-ion battery in a dry and protected location. Pay attention to the storage conditions; see chapter 2.2.4. Ambient Conditions.
- ▶ In the event of a fire, use a CO₂ fire extinguisher or a fire extinguisher with non-conductive foam. Please proceed as follows:
 - Step 1: **Extinguish** with CO₂ fire extinguisher / fire extinguisher with non-conductive foam
 - Step 2: **Cool** with CO₂ fire extinguisher / fire extinguisher with non-conductive foam
 - Step 3: **Isolate** -> Place the lithium-ion battery in a secure location for at least seven days and also cover it with sand.

7.3. Winter Storage

The winter storage process is primarily focussed on maritime and outdoor applications.

The lithium-ion battery can be operated between $-20\text{ }^{\circ}\text{C}$ to $+60\text{ }^{\circ}\text{C}$.

For applications in which temperatures fall below $0\text{ }^{\circ}\text{C}$ and application operation is shut down (e. g. in maritime applications), we recommend a winter storage process.

The lithium-ion battery can stay in its installation location for the duration of the winter at temperatures down to $-20\text{ }^{\circ}\text{C}$ (low-temperature periods).

If ambient temperatures drop below $-20\text{ }^{\circ}\text{C}$, this could lead to premature ageing of the lithium-ion battery. For this reason, the lithium-ion battery should be stored in a temperature-controlled environment between $0\text{ }^{\circ}\text{C}$ to $+30\text{ }^{\circ}\text{C}$.

For winter storage, please proceed as follows:

1. Charge the lithium-ion battery between 50 % to 80 % SoC (enables a storage time of at least two years).
 2. Set the power switch to "OFF".
 3. If necessary, remove the (+) / (-) power cable.
- ✓ The lithium-ion battery is now ready to be stored over the winter period.

7.4. Disposal and Recycling

Once the lithium-ion battery has reached the end of its service life, its safe and professional disposal must be ensured during decommissioning, especially with respect to parts or substances harmful to the environment.

Dispose of the lithium-ion battery in a proper manner in accordance with local statutory regulations and rules governing lithium-ion technologies. Please also bear aentron's recycling service in mind at www.aentron.com/recycling

To prevent environmental hazards, an approved specialist contractor must be commissioned with disposal. NEVER dispose of the lithium-ion battery in domestic waste / residual waste.

Dispose of materials which can be sent for recycling properly, always keeping our environment in mind.



8. Faults and Notifications

8.1. Troubleshooting

Fault	Cause	Remedy
The battery is not discharging	Battery voltage is within the operating voltage range: 12 V: 10.5 to 16.4 Vdc 24 V: 21 to 28.7 Vdc 48 V: 42 to 57.4 Vdc	Check that the power cables are properly connected.
	The status LED is either yellow or green.	Check that the power cables are properly connected.
	The battery is in shutdown mode. The status LED is not illuminated.	Switch the battery on at the E-Switch.
	The status LED is red or flashes red. Undervoltage warning	Charge the battery.
	The battery is in safety mode. a) Battery experiencing over temperature: > +60 °C b) Battery experiencing under temperature: < -10 °C	a) Allow the battery to cool down to < +40 °C b) heat up the battery to > 0 °C
	With the E-Switch activated, the battery is still at 0 V and battery-charging is attempted.	The fuse has blown. Refer to your authorised aentron dealer.
During the charging process, the battery becomes hot (> +50 °C)	Lithium-ion Battery cells are damaged.	Stop the charging process immediately. Isolate the battery for > 24 hours as a preventive measure. Refer to your authorised aentron dealer.
During the discharge process, the battery becomes hot (> +50 °C)	Lithium-ion Battery cells are damaged.	Reduce load current immediately or stop for 15 minutes so that the battery can cool down (< +40 °C). Isolate battery for > 24 hours as a preventive measure. Refer to your authorised aentron dealer.

Fault	Cause	Remedy
The battery stops unexpectedly, even though the status LED is green.	Threshold exceeded a) Over-current (> 60 A) b) Over temperature (> +60 °C)	a) Switch off the load and wait 60 seconds. Switch the battery back on again. b) Keep the battery away from heat sources (e. g. engine rooms).
The battery stops unexpectedly, even though the status LED is yellow.	Threshold exceeded a) Over-current (> 60 A) b) Over temperature (> +60 °C) c) Undervoltage	a) Switch off the load and wait 60 seconds. Switch the battery back on again. b) Keep the battery away from heat sources (e. g. engine rooms). c) Reduce the load current to a value which prevents the undervoltage level from being exceeded, or charge the battery.
The battery capacity degrades faster than expected.	Premature ageing is caused by: a) Operation at low temperatures (< -10 °C) b) Operation at high temperatures (> +40 °C) c) Mean operational discharge current is above the C-rate d) The average charge current is above 1 C.	a) Prevent prolonged operation below 0 °C. b) Prevent prolonged operation above +40 °C. c) With average operating current, keep to the values of a maximum of 0.7 C as much as possible. d) The average charge current should not be more than 0.5 C.

8.2. Emergencies

Switch the lithium-ion battery off and disconnect all electrical connections:

- In the event of injury.
- If there is a risk that the lithium-ion battery will be damaged.

In the event of an accident, take immediate measures and call the local emergency services number.

In the event of a fire, use a CO₂ fire extinguisher or a fire extinguisher with non-conductive foam. Please proceed as follows:

- Step 1: **Extinguish** with CO₂ fire extinguisher / fire extinguisher with non-conductive foam
- Step 2: **Cool** with CO₂ fire extinguisher / fire extinguisher with non-conductive foam
- Step 3: **Isolate** -> Place the lithium-ion battery in a secure location for at least seven days and also cover it with sand.

Remove the lithium-ion battery in the event of a short circuit or overcharge and isolate it for 24 - 48 hours to prevent internal cell short circuit (slow-burn short circuit).

8.3. Frequently Asked Questions (FAQ)

What is the best way to put the lithium-ion battery into operation?

- aentron lithium-ion batteries are delivered with a charge level of between 30 % to 50 % SoC, and must be fully charged prior to use.
- It is normal for the battery to feel warm to touch during charging and discharging.

How maintenance-intensive is the lithium-ion battery?

- Under normal operating conditions and moderate ambient conditions, aentron lithium-ion batteries are maintenance-free.

What is the lithium-ion chemistry of the lithium-ion battery?

- aentron lithium-ion batteries are based on nickel manganese cobalt chemistry (NMC).
- Li-NMC delivers approx. 70 % more energy density compared to lithium-iron-phosphate formulae (LiFePO₄).

Can the lithium-ion batteries be installed in any location?

- Yes. Mounting holes are provided and a mounting rail set is available as an optional extra.

Can the lithium-ion batteries withstand vibrations and shocks?

- Yes. Our customer's areas of application range from boats to off-road vehicles. The lithium-ion batteries are encased with aluminium die-cast housings.

What is the service life of a lithium-ion battery?

- Service life depends on the application. In general, aentron lithium-ion batteries have a service life of more than ten years. A requirement for this is operation within the permissible voltage range (max. 80 % discharge depth) at room temperature.
- aentron lithium-ion batteries can perform 3,000 complete charge / discharge cycles (with a max. discharge depth of 80 %).
- To ensure as long a service life as possible, extreme temperatures should be avoided during operation (extreme cold or heat).
- You reach the maximum service life in a SoC range of between 20 % and 90 %.

I heard that lithium-ion batteries are unstable and pose a fire hazard.

aentron lithium-ion batteries are safe, robust and fitted with safety features that go beyond industry standards:

- Waterproof housing
- Robust aluminium die-cast housing
- Battery management system integrated as standard
- Innovative cooling system for the cells
- High-grade cells
- Fire-resistant components
- Units have been tested and have fulfilled all current industry standards and regulations.

How high is the rate of self-discharge for lithium-ion batteries?

- Self-discharge is the loss of usable capacity of a battery due to internal chemical reactions. Self-discharge takes place in all battery chemicals and is influenced by temperature.
Self-discharge occurs regardless of whether a battery is connected to a device or not.
- When an aentron lithium-ion battery is switched off, the average rate of self-discharge is 2 % to 4 % per year.
- We recommend charging the battery to a charge level of at least 50 % once per year. 2-year storage capability is guaranteed ex works, in any case.

What are the best operation and storage temperatures?

- Temperature fluctuations can have a dramatic effect on the performance and service life of every battery. High temperatures ($> +40\text{ °C}$) intensify the chemical reactions inside the battery and can lead to premature ageing of the battery. Low temperatures ($< 10\text{ °C}$) can slow down chemical processes so much that battery performance might not meet the requirements of the load.
- Ideally, batteries should be stored / charged at 50 % to 80 % SoC between $+10\text{ °C}$ to 25 °C and operated at 0 °C to $+30\text{ °C}$.

How do I maximise battery service life?

- Always store the battery in a cool and dry place. Ensure that the battery is charged to 50 % to 80 % SoC before storing it for long periods.

How do I dispose of the lithium-ion battery?

- aentron lithium-ion batteries are wholly recyclable. Information can be found at www.aentron.com/recycling

Do the lithium-ion batteries require cell balancing?

- All lithium-ion batteries from aentron GmbH boast integrated, passive cell balancing as standard.
- Cell balancing ensures for maximum performance of the lithium-ion battery and maximises service life.

Do the lithium-ion batteries require special handling during transport?

- Yes. All lithium-ion batteries are considered to be dangerous goods.
- In all other respects, the battery does not require any special treatment beyond the customary preventive measures.

9. Legal Information

9.1. Warranty Conditions

Please observe our warranty conditions and T&Cs at www.aentron.com/agb

9.2. Copyright and Property Rights

All the content of this operating manual is the intellectual property of aentron GmbH and is subject to protection under copyright law.

The product and the word / figurative marks are legally protected.

All reproduction, editing, distribution, handover to third parties, even just excerpts, and any form of exploitation beyond the limits of copyright law require the written consent of aentron GmbH.

In the event of any infringements, aentron GmbH reserves the right to take legal action.

We reserve the right to make changes to this operating manual and changes to technical details in terms of the specifications and illustrations in this operating manual.

All names of products referred to in this operating manual are trademarks of the respective companies and are recognised as such.

9.3. Material and Legal Defects

Claims of the operator concerning material and legal defects require that such complaints be raised in writing without delay, but within two working days at the latest.

aentron GmbH assumes no liability for damage caused by:

- Misuse or non-observance of the operating manual and / or the requirements therein.
- Misuse or damage caused by improper handling, transport, storage or repackaging which was not provided or arranged by aentron GmbH.
- Modifications or repairs to the lithium-ion battery which are not authorised by aentron GmbH.
- Corrosion due to the effect of aggressive atmospheres or environmental conditions beyond the permissible operating and ambient conditions.
- Non-observance of the applicable safety regulations.
- Aesthetic or superficial faults which impair neither the form, value nor functioning of the product.

If aentron GmbH is responsible for a defect, aentron GmbH is entitled to provide subsequent improvement or supply a replacement at its discretion.

No claims are made as to the ability to supply previous versions or the ability to upgrade delivered devices to the latest version.

9.4. Approvals and EU Declaration of Conformity

The Declaration of Conformity and other documents can be found at www.aentron.com/downloads

Approvals	
UN Manual of Tests and Criteria for the Transport of Lithium-Ion Batteries	UN Manual of Tests and Criteria Part III, Sub-Section 38.3 (DGR 3.9.2.2.6)
IATA Transport	SP 188 / PI965, Part II IATA, packaging instructions
IATA Transport	SP 230, special regulation
IP 66 (IEC 60529)	≥ IP67X (IEC60529) [DIN 40050-9]
Environmental compatibility	Directive 2013/56/EC of the Council, compliance with EU environment regulations
IEC 60068-2-2-27	Environmental Audit - Part 2-27: Tests
EMC	Directive 2014/30/EC of the Council on electromagnetic compatibility
IEC 61000 -4-2,3,4,4,5,6,6,7,8,11	Electromagnetic Compatibility (EMC)
IEC 62281	Safety or primary and secondary lithium cells and batteries during transport
IEC 62619	Safety requirements for secondary lithium cells and batteries for use in industrial applications
Low-Voltage Directive (2014/35/EC)	Ensures that all electric operating equipment is within given voltage limits
2006/42/EC	Machinery Directive
95/465/EEC	E-marking - Harmonisation of legal regulations of member states concerning electrical operating equipment intended for use within given voltage limits.
UV assessment	UV assessment (ASTM D 2565) (not legally binding)
IEC 60707 (UL 94 V0)	UL94 V0 Verification of the fire-resistance of plastics (not legally binding)
German Battery Act (2006/66/EC)	German Battery Act (2006/66/EC) Recycling coordinator for Germany GRS-Batterien www.grs-batterien.de
RoHS	Directive 2011/65/EC for the restriction of use of certain hazardous substances in electrical and electronic devices
Waste Electrical and Electronic Equipment (WEEE)	DE 50419 (2006)

Approvals	
Recycling	IEC 61429/A11 (1998)
EN ISO 9001:2015	Quality management
EN ISO 16315:2016	Small craft - Electrical drive systems
ISO 7000:2012	Graphical Symbols for Use on Equipment - Registered symbols, Edition: 4
IEC 60417:2002	Graphical Symbols for Use on Equipment - Registered symbols
IEC 62133 Ed2.0	Secondary cells and batteries containing alkaline or other non-acidic electrolytes - Safety requirements for portable sealed secondary cells, and for batteries made from them, for use in portable applications

aentron | ENERGY
SOLUTIONS

aentron GmbH
Friedrichshafener Straße 7
82205 Gilching
GERMANY

Phone.: +49 8105 398 98-0
Fax: +49 8105 398 98-29
Email: info@aentron.com